

REVISIONS			
REV.	DESCRIPTION	DATE	APPROVED
-	NEW RELEASE	-	
1		4/21/2026	

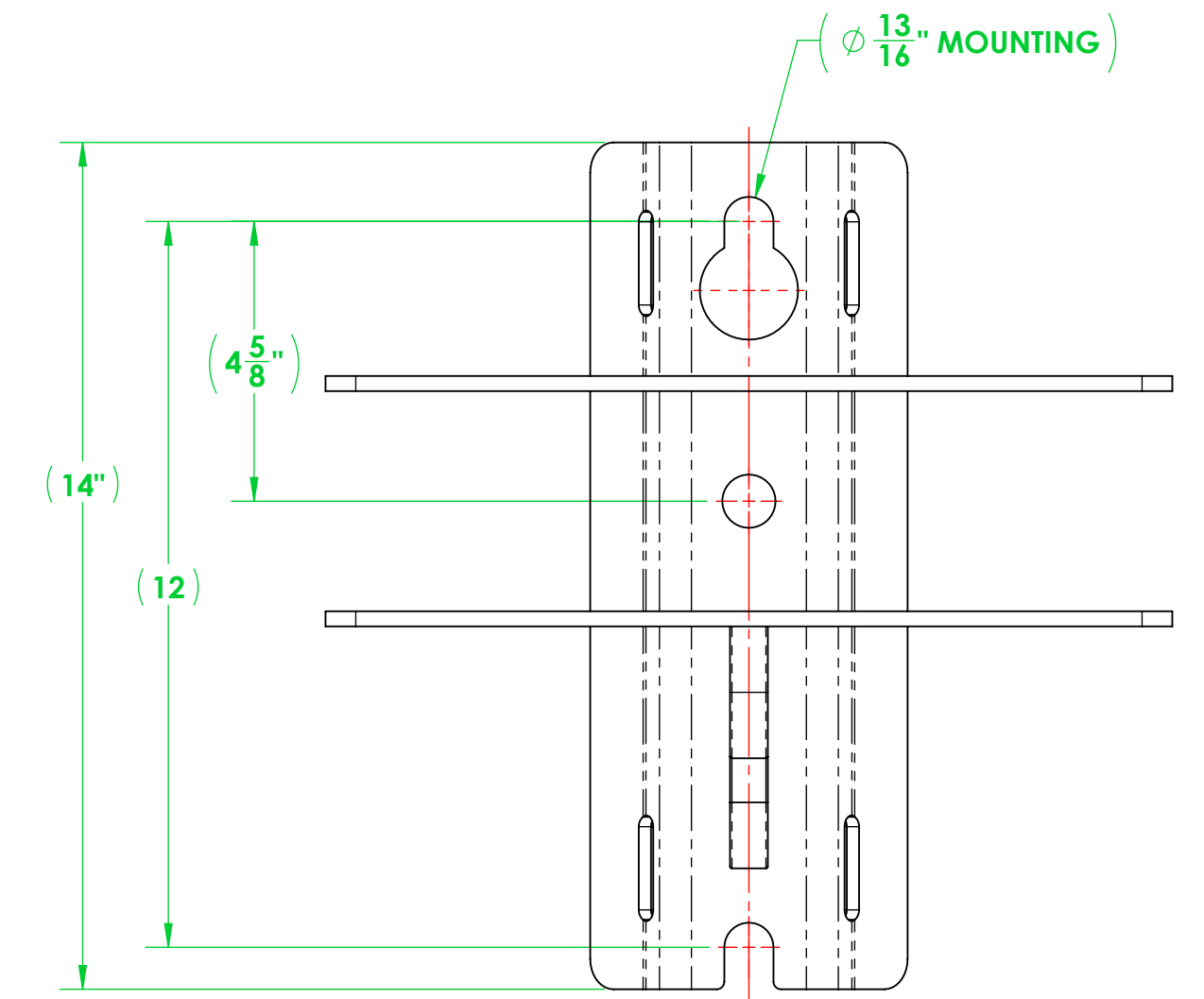

DETAIL A

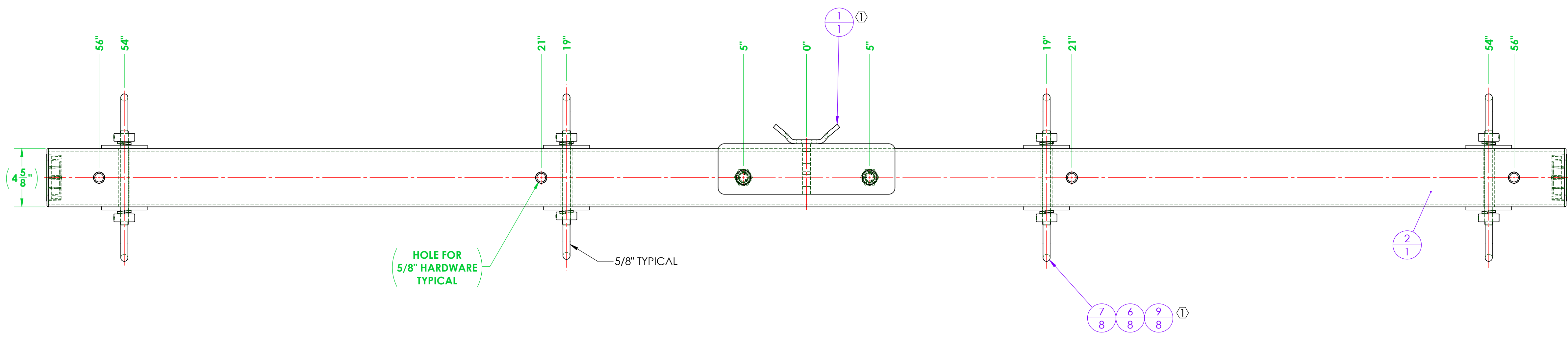
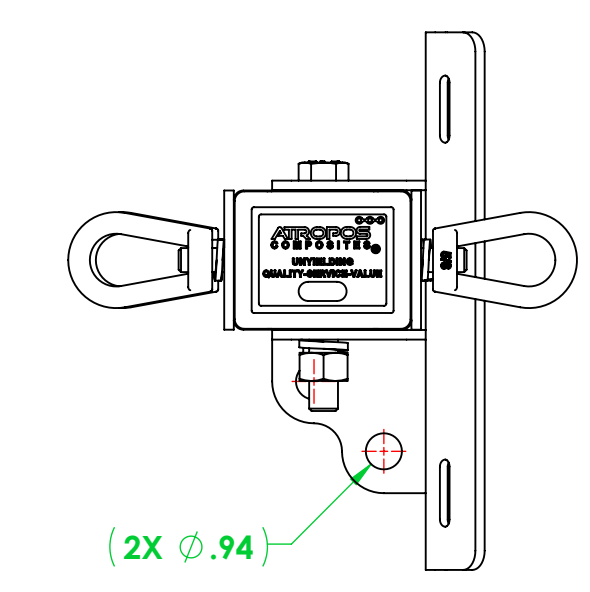
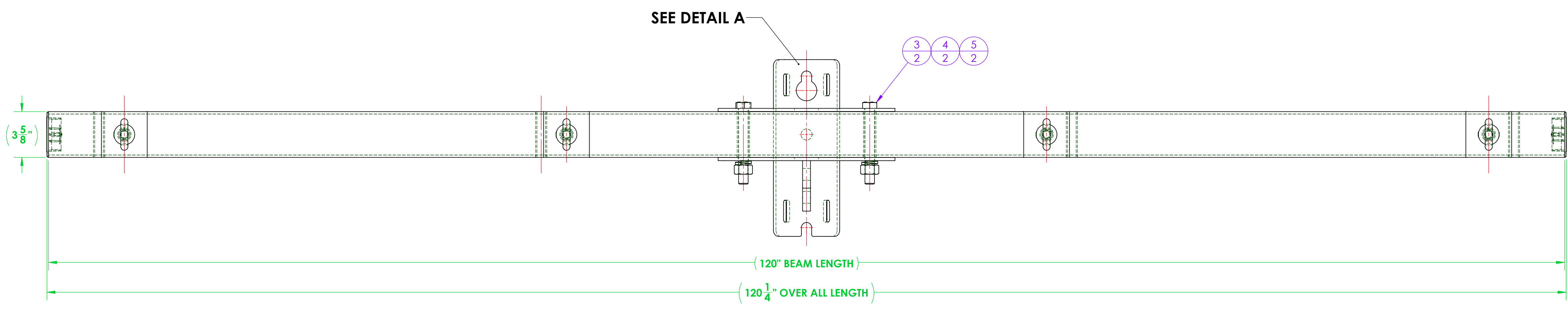

ITEM NO.	PART NUMBER	DESCRIPTION	QTY.
① 1	A700-0044	CROSSARM MOUNTING BRACKET, DEADEND, 3400 SERIES	1
2	3401A120-D312-4R10 CA	ASSEMBLY, 3401 DEADEND CROSSARM, 10'	1
3	A616-0020-02	BOLT, HEX, 3/4"-10 X 6.00" LONG, HOT DIPPED GALVANIZED STEEL, 1-1/8" DRIVE	2
4	A616-0042-01	LOCK WASHER, FOR 3/4" SCREW, 0.766" ID, 1.265" OD, 0.188" THICK, HOT-DIPPED GALVANIZED STEEL	2
5	A616-0019-02	EXTREME STRENGTH NUT, HEX, 3/4"-10, 2H, HOT-DIPPED GALVANIZED	2
6	A616-0042-02	LOCK WASHER, FOR 5/8" SCREW, 0.641" ID, 1.073" OD, 0.156" THICK, HOT-DIPPED GALVANIZED STEEL	8
7	A616-0017-02	EYENUT, 5/8"-11, GALVANIZED STEEL	8
8	A711-0044	ALL-THREAD, 5/8"-11 X 7.50" LONG, GALV. STEEL	4
① 9	A700-0049	WASHER, SQUARE, 3.625" X 3.625" X 0.25 THICK WITH 0.66 THRU HOLE	8

GENERAL NOTES	UNLESS OTHERWISE SPECIFIED	NAME	DATE						
	DIMENSIONS ARE IN INCHES STANDARD TOLERANCES	DRAWN: F. BRYANT	10/16/2025						
	FRACTIONAL: ±1/32	CHECKED: TJS	10/21/2025						
	ANGULAR: MACHINED: +0.5° BEND: ±2°	ENG APPR:							
	TWO PLACE DECIMAL: ±0.03	MFG APPR:							
	THREE PLACE DECIMAL: ±0.005	Q.A.:							
	INTERFERENCE GEOMETRIC TOLERANCING PER: ANSI Y14.5								
	MATERIAL	PROPRIETARY AND CONFIDENTIAL							
	FINISH	THE INFORMATION CONTAINED IN THIS DRAWING IS THE SOLE PROPERTY OF VECTUS. ANY REPRODUCTION IN PART OR AS A WHOLE WITHOUT THE WRITTEN PERMISSION OF VECTUS IS PROHIBITED.							
DO NOT SCALE DRAWING		<table border="1"> <tr> <td>SIZE</td> <td>DWG. NO.</td> <td>REV</td> </tr> <tr> <td>1:8</td> <td>D3401A120-D312-4R10</td> <td>1</td> </tr> </table>		SIZE	DWG. NO.	REV	1:8	D3401A120-D312-4R10	1
SIZE	DWG. NO.	REV							
1:8	D3401A120-D312-4R10	1							

ATROPOS
COMPOSITES

12208 MISSOURI BOTTOM ROAD, HAZELWOOD, MO 63042
PHONE: 314.714.4001 FAX: 314.895.1943
SALES@LABYRINTH-TECH.COM

TITLE:
ASSEMBLY, RUS, 3401 DEADEND
CROSSARM WITH GAIN, 10'

SCALE: 1:8 WEIGHT: 78.68 SHEET 1 OF 1